

# SUMITOMO



**SUPER LONG REACH**

**SH210LC-6LR  
SH250-6LR**

*LEGEST*

ASEAN SPEC

SH210LC-6LR  
SH250-6LR

**A powerful partner for  
riverside and shoreline repair work  
as well as shoreline dredging**



## ENGINEERED IN JAPAN

The world knows that Japanese designed and engineered products represent the highest quality, especially for Industrial Products. The hydraulic excavator is no exception when a totally integrated concept is required in design work involving key components, manufacturing engineering, and product quality assurance in the factory.

SUMITOMO hydraulic excavators are designed and manufactured today to meet the global demands of our many customers with the concept of Performance, Reliability, and Fuel Efficiency foremost in our minds. This proven Japanese technology and quality gives SUMITOMO excavator customers total peace of mind and provide a complete solution for the demands of the construction industry.

New Engine System



New Hydraulic System



Reduction in Fuel Consumption

SH210LC-6LR **16%**

SH250-6LR **18%**

(as compared with S series (H model))

## New Generation Engine System "SPACE 5+"

The new engine system optimises fuel efficiency and environmental performance via the advanced common rail fuel injection system, and turbocharger.

At the same time, excellent response times are achieved.

## Mode Selection by Throttle

SUMITOMO  
CONSTRUCTION

There are three working modes available: SP (Super Power) for heavy duty applications, H (Heavy) for normal working conditions, A (Auto) for a wide range of operations.



## Further Improvement of Fuel Consumption

The new technology has improved operations and reduced fuel consumption on each working mode.

### Reduction in Fuel Consumption

SH210LC-6LR SH250-6LR

• SP mode **16%** • SP mode **11%**

• H mode **16%** • H mode **18%**

(as compared with S series)

\*Fuel consumption may vary from time to time depending on site and working conditions, operator skill and other circumstances.

## Automatic Power Boost

The digging power increases automatically in quick response to the working conditions during heavy-duty digging work. This is a design unique to SUMITOMO, and continues for eight seconds (SP/H mode).

## SH250-6LR

Operating weight : 28 300kg  
Rated output (ISO 14396) :  
140 kW at 2 000 min<sup>-1</sup>  
Ground pressure : 42kPa (with 800mmGS)  
Max digging radius : 18 330mm

## SH210LC-6LR

Operating weight : 23 200kg  
Rated output (ISO 14396) :  
122kW at 1 800min<sup>-1</sup>  
Ground pressure : 36kPa (with 800mmGS)  
Max digging radius : 15 610mm



# SH210LC-6LR SH250-6LR SUPER LONG REACH

## Principle Specifications

	SH210LC-6LR	SH250-6LR
<b>Boose</b>		
Boom length	8.7 m	10.3 m
Arm length	6.4 m	8.0 m
Bucket capacity (ISO heaped)	0.37 m <sup>3</sup>	0.37 m <sup>3</sup>
Std. operating weight	23 200 kg	28 300 kg
Make & model	ISUZU GF-4HK1X	ISUZU GH-4HK1X
Rated output (ISO 14396)	122 kW at 1 800 min <sup>-1</sup>	140 kW at 2 000 min <sup>-1</sup>
Displacement	5 193 cc	5 193 cc
<b>Hydraulic System</b>		
Main pump	2 variable displacement axial piston pumps with regulating system	2 variable displacement axial piston pumps with regulating system
Max pressure (with auto power boost)	34.3 (36.8) MPa	34.3 (36.8) MPa
Travel motor	Variable displacement axial piston motor	Variable displacement axial piston motor
Parking brake type	Mechanical disc brake	Mechanical disc brake
Swing motor	Fixed displacement axial piston motor	Fixed displacement axial piston motor
<b>Performance</b>		
Travel speed	5.6 / 3.4 km/h	5.5 / 3.5 km/h
Drawbar pull	187 kN	199 kN
Grade ability	70% <35°	70% <35°
Ground pressure	36 kPa (with 800 mm GS)	42 kPa (with 800 mm GS)
Swing speed	11.5 min <sup>-1</sup>	11.0 min <sup>-1</sup>
Bucket digging force	65 kN	77 kN
Arm digging force	46 kN	40 kN
Fuel tank	410 liter	410 liter
Hydraulic fluid tank	147 liter	147 liter

## Working Range

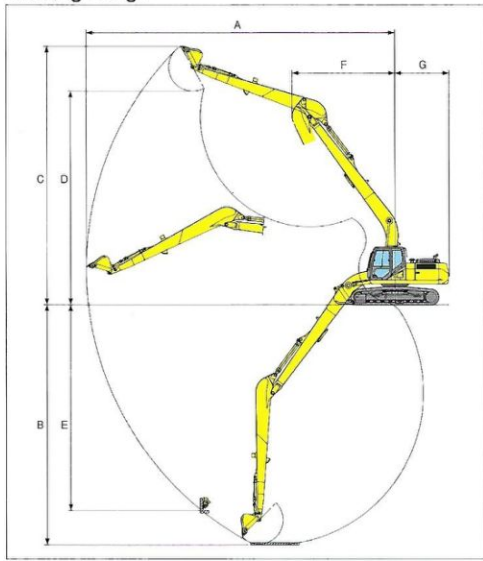

	SH210LC-6LR	SH250-6LR
Boom length	8.7 m	10.3 m
Arm length	6.4 m	8.0 m
A Max digging radius	15 610 mm	18 330 mm
B Max digging depth	12 020 mm	14 570 mm
C Max digging height	12 970 mm	13 960 mm
D Max dumping height	10 720 mm	11 770 mm
E Max vertical wall cut depth	10 290 mm	12 140 mm
F Min front swing radius	5 190 mm	6 220 mm
G Rear end swing radius	2 750 mm	2 950 mm

## Dimensions

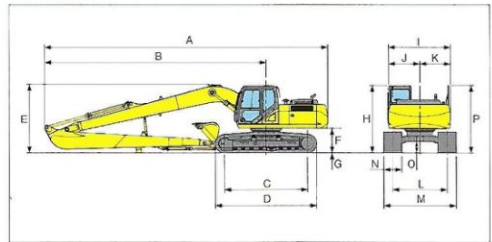

	SH210LC-6LR	SH250-6LR
Boom length	8.7 m	10.3 m
Arm length	6.4 m	8.0 m
A Overall length	12 470 mm	14 380 mm
B Length from centre of machine (to arm top)	9 750 mm	11 440 mm
C Centre to centre of wheels	3 660 mm	3 840 mm
D Overall track length	4 470 mm	4 650 mm
E Overall height (to top of boom)	3 000 mm	3 130 mm
F Clearance height under upper structure	1 040 mm	1 100 mm
G Shoe lug height	26 mm	26 mm
H Overall height (to top of cab)	2 950 mm	3 010 mm
I Upper structure overall width	2 770 mm	2 770 mm
J Width from centre of machine (left side)	1 430 mm	1 430 mm
K Width from centre of machine (right side)	1 340 mm	1 340 mm
L Track gauge	2 390 mm	2 590 mm
M Overall width	3 190 mm	3 390 mm
N Std. shoe width	800 mm	800 mm
O Minimum ground clearance	440 mm	440 mm
P Overall height (to top of handrail)	3 120 mm	3 180 mm

## Bucket

		SH210LC-6LR	SH250-6LR
Bucket capacity	STD	0.37 m <sup>3</sup>	0.37 m <sup>3</sup>
	(ISO heaped)	0.45 m <sup>3</sup>	0.45 m <sup>3</sup>
	OPT*		

\*Limited use only for dredging work



**PT. SUMITOMO S.H.I.**  
**CONSTRUCTION MACHINERY INDONESIA**

Jl. Maligi VIII Lot T-1, Kawasan Industri KIIC Telukjamba Barat, Karawang, Jawa Barat 41361  
Tel : +62-21-8910-8686 Fax : +62-267-863-1790



**PT. SUMITOMO S.H.I.**  
**CONSTRUCTION MACHINERY SOUTHEAST ASIA**

Wisma GKBI 16th floor, Jl.Jend. Sudirman No.28, Jakarta 10210  
Tel : +62-21-5795-2254 Fax : +62-21-5795-1210

<http://www.sumitomokenki-asean.com/>

We are constantly improving our products and therefore reserve the right to change designs and specifications without notice. Illustrations may include optional equipment and accessories and may not include all standard equipment.



# SH210LC-6LR SH250-6LR SUPER LONG REACH

## Principle Specifications

	SH210LC-6LR	SH250-6LR
<b>Boose</b>		
Boom length	8.7 m	10.3 m
Arm length	6.4 m	8.0 m
Bucket capacity (ISO heaped)	0.37 m <sup>3</sup>	0.37 m <sup>3</sup>
Std. operating weight	23 200 kg	28 300 kg
Make & model	ISUZU GF-4HK1X	ISUZU GH-4HK1X
<b>Engine</b>		
Rated output (ISO 14396)	122 kW at 1 800 min <sup>-1</sup>	140 kW at 2 000 min <sup>-1</sup>
Displacement	5 193 cc	5 193 cc
<b>Hydraulic System</b>		
Main pump	2 variable displacement axial piston pumps with regulating system	2 variable displacement axial piston pumps with regulating system
Max pressure (with auto power boost)	34.3 (36.8) MPa	34.3 (36.8) MPa
Travel motor	Variable displacement axial piston motor	Variable displacement axial piston motor
Parking brake type	Mechanical disc brake	Mechanical disc brake
Swing motor	Fixed displacement axial piston motor	Fixed displacement axial piston motor
<b>Performance</b>		
Travel speed	5.6 / 3.4 km/h	5.5 / 3.5 km/h
Drawbar pull	187 kN	199 kN
Grade ability	70% <35°>	70% <35°>
Ground pressure	36 kPa (with 800 mm GS)	42 kPa (with 800 mm GS)
Swing speed	11.5 min <sup>-1</sup>	11.0 min <sup>-1</sup>
Bucket digging force	65 kN	77 kN
Arm digging force	46 kN	40 kN
Fuel tank	410 liter	410 liter
<b>Others</b>		
Hydraulic fluid tank	147 liter	147 liter

## Working Range

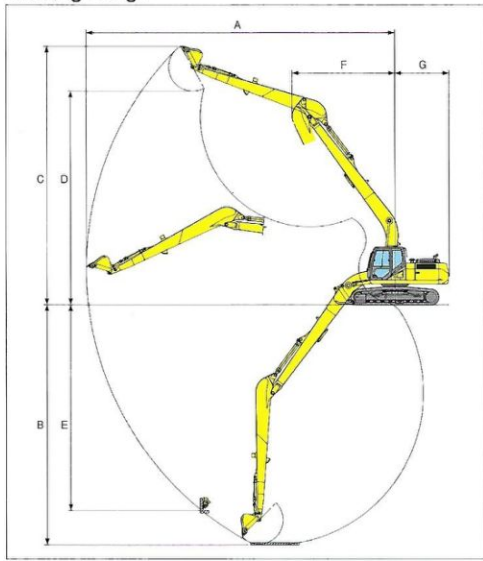

	SH210LC-6LR	SH250-6LR
Boom length	8.7 m	10.3 m
Arm length	6.4 m	8.0 m
A Max digging radius	15 610 mm	18 330 mm
B Max digging depth	12 020 mm	14 570 mm
C Max digging height	12 970 mm	13 960 mm
D Max dumping height	10 720 mm	11 770 mm
E Max vertical wall cut depth	10 290 mm	12 140 mm
F Min front swing radius	5 190 mm	6 220 mm
G Rear end swing radius	2 750 mm	2 950 mm

## Dimensions

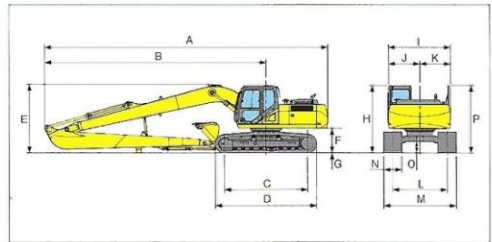

	SH210LC-6LR	SH250-6LR
Boom length	8.7 m	10.3 m
Arm length	6.4 m	8.0 m
A Overall length	12 470 mm	14 380 mm
B Length from centre of machine (to arm top)	9 750 mm	11 440 mm
C Centre to centre of wheels	3 660 mm	3 840 mm
D Overall track length	4 470 mm	4 650 mm
E Overall height (to top of boom)	3 000 mm	3 130 mm
F Clearance height under upper structure	1 040 mm	1 100 mm
G Shoe lug height	26 mm	26 mm
H Overall height (to top of cab)	2 950 mm	3 010 mm
I Upper structure overall width	2 770 mm	2 770 mm
J Width from centre of machine (left side)	1 430 mm	1 430 mm
K Width from centre of machine (right side)	1 340 mm	1 340 mm
L Track gauge	2 390 mm	2 590 mm
M Overall width	3 190 mm	3 390 mm
N Std. shoe width	800 mm	800 mm
O Minimum ground clearance	440 mm	440 mm
P Overall height (to top of handrail)	3 120 mm	3 180 mm

## Bucket

	SH210LC-6LR	SH250-6LR
Bucket capacity	STD	0.37 m <sup>3</sup>
(ISO heaped)	OPT*	0.45 m <sup>3</sup>

\*Limited use only for dredging work

### PT. SUMITOMO S.H.I. CONSTRUCTION MACHINERY INDONESIA

Jl. Maligi VIII Lot T-1, Kawasan Industri KIIC Telukjamba Barat, Karawang, Jawa Barat 41361  
Tel : +62-21-8910-8686 Fax : +62-267-863-1790

### PT. SUMITOMO S.H.I. CONSTRUCTION MACHINERY SOUTHEAST ASIA

Wisma GKBI 16th floor, Jl.Jend. Sudirman No.28, Jakarta 10210  
Tel : +62-21-5795-2254 Fax : +62-21-5795-1210

<http://www.sumitomokenki-asean.com/>

We are constantly improving our products and therefore reserve the right to change designs and specifications without notice. Illustrations may include optional equipment and accessories and may not include all standard equipment.